

# General Specifications

GS 04L55B01-01EN

## Data Acquisition System GM

**SMARTDAC+**

GM10 Data Acquisition Module  
GM90MB Module Base  
GM90PS Power Supply Module

### OVERVIEW

The Data Acquisition System GM is a data logger that excels in versatility and expandability. The main unit includes on-board memory for data acquisition and also supports SD cards for external storage. The system consists of a Data Acquisition Module (GM10), Power Supply Module (GM90PS), and Module Base (GM90MB), which is used to mount a variety of modules.

SMARTDAC+ GM utilizes the same modules as the GX/GP series of SMARTDAC+.

- High expandability and maintainability:** Employs YOKOGAWA's original block structure, making it easy to rearrange the combination of required modules. The structure also excels in maintainability because even after installation, every module can be removed separately.
- Multichannel measurement:** Measures up to 420 analog input channels on the GM10-2 and up to 100 channels even on the GM10-1.
- Flexible system configuration:** A wide variety of systems, such as multichannel measurement from 10 to 420 channels or data acquisition through communication, can be configured.
- High environmental tolerance:** The guaranteed operating temperature range of -20°C to 60°C allows more freedom in where the system can be installed.
- Mounting:** Not only can the system be installed on a desktop, it can also be mounted on DIN rails or a wall.
- Less wiring through distribution:** Installation of sub units away from the main unit makes measurement possible without connecting sensor signal wires over a long distance.
- Long-term recording and saving:** Large internal memory (500 MB on the GM10-1 and 1.2 GB on the GM10-2) allows long-term recording and saving.
- Secure saving of recording data:** An SD card (SD/SDHC) up to 32 GB (1 GB included) can be used for the external storage medium. And the FTP client function can be used to provide data redundancy using a file server.
- Rich I/O interface:** Five types of I/O modules are available: analog input, digital input, digital output, digital I/O, and pulse input. DCV (DC voltage), TC (thermocouple), RTD (resistance temperature detector), DI (contact or TTL level voltage), mA (DC current) can be assigned to each channel as input signals.
- Web server function:** Various settings can be configured online from a Web browser, without using a dedicated software application. Moreover, measured data can be monitored in real time.
- Simple settings:** The standard USB port makes it easy to configure various settings offline from a PC.
- Supports 21 CFR Part 11:** GM supports the USA FDA's Title 21 CFR Part 11 regulation.
- Extensive network functions:** The standard Ethernet interface allows network features such as various e-mail notifications and FTP file transfer. In addition, Modbus/TCP, Modbus/RTU (/C3), and EtherNet/IP (/E1) are supported.



- Universal Viewer software:** A free software application is available for displaying and printing waveforms of measured data on a PC.
- Actual values underlying accurate measurements**

Input Type		Measuring accuracy <sup>1</sup> (typical value <sup>2</sup> )
DCV	20 mV	± (0.01% of rdg + 5 μV)
	60 mV	± (0.01% of rdg + 5 μV)
	6V (1-5V)	± (0.01% of rdg + 2 mV)
TC <sup>3</sup>	R	±1.1°C
	K	± (0.01% of rdg + 0.2°C for 0.0 to 1370.0°C; ± (0.15% of rdg + 0.2°C) for -200.0 to 0.0°C
	K (-200 to 500°C)	±0.2°C for 0.0 to 500.0°C; ± (0.15% of rdg + 0.2°C) for -200.0 to 0.0°C
	J	± 0.2°C for 0.0 to 1100.0 °C; ± (0.10% of rdg + 0.2 °C) for -200.0 to 0.0 °C
	T	± 0.2°C for 0.0 to 400.0°C; ± (0.10% of rdg + 0.2 °C) for -200.0 to 0.0 °C
	N	± (0.01% of rdg + 0.2°C) for 0.0 to 1300.0 °C; ± (0.22% of rdg + 0.2°C) for -200.0 to 0.0 °C
RTD	Pt100	± (0.02% of rdg + 0.2°C)
	Pt100 (high resolution)	± (0.02% of rdg + 0.16°C )

rdg: Reading value

\*1 These values have been calculated from the accuracy testing data at the time of shipment of the instrument from the factory. Applies to GX90XA-10-U2, A/D integration time 16.67 ms or more, General operating conditions: 23±2 °C, 55±10% RH, supply voltage 90–132, 180–264 V AC, power frequency within 50/60 Hz ±1%, warm-up of 30 minutes or more, no vibrations or other hindrances to performance.

\*2 For the measuring accuracy (guaranteed), see the module's general specifications (GS 04L53B01-01EN).

\*3 These values do not include the reference junction compensation accuracy.

## ■ CONFIGURATION

SMARTDAC+ GM handles a wide variety of applications through the combination of various modules.

The unit that includes GM10 (Data Acquisition Module) is called the *main unit*. A unit connected to the main unit via GX90EX (expansion module) is called a *sub unit*. Modules in a unit can be connected by installing a GM90MB (Module Base).

### ● Unit Types

#### Main Unit (Single Unit)

A unit consisting of a GM10 and a GM90PS. Up to 10 I/O modules\* can be connected to a unit.



\* Up to 8 when a GX90XA-T1 is connected

#### Main Unit (Multi Unit)

A unit consisting of a GM10, a GM90PS and a GX90EX. Up to six I/O modules can be connected to a unit. Up to six sub units can be connected via the GX90EX.



#### Sub Unit

A unit consisting of a GM90PS and a GX90EX. Up to six I/O modules can be connected to a unit. The main unit and sub units are connected using LAN cables. The maximum connection distance between two units is 100 m.



### ● Module Types

Model	Description
GM10	Data Acquisition Module for SMARTDAC+ GM A module that acquires data from I/O modules and expansion modules. A main unit requires one module of this type.
GM90PS	Power Supply Module for SMARTDAC+ GM A module that supplies power to the modules connected in the unit. A unit requires one module of this type.
GX90EX*	Expansion module A module that connects units to expand the system. A main unit or a sub unit requires one module of this type.

\* The firmware version of GX90EX that can be used on the SMARTDAC+ GM must be R1.02.01 or later.

Model	Description
GM90MB	Module Base This is used to connect modules (excluding the GM90PS).

For the detailed specifications of the expansion module, see the following general specifications.

Material No.: GS 04L53B00-01EN

### I/O Modules

The firmware version of I/O modules that can be used on the SMARTDAC+ GM must be R1.04.01 or later.



Model	Description
GX90XA	Analog input module (number of inputs: 10) A module that can receive various analog signals.
Type Suffix code	
-U2	Universal, solid state relay scanner type (3-wire RTD b-terminal common) DC voltage, standard signal, thermocouple, resistance temperature detector (RTD), DI (voltage, contact), DC current (when an external shunt resistor is connected) Scan interval: 100/200/500 ms, 1/2/5 s Power consumption: 0.7 W
-C1	Current (mA), scanner type (isolation between channels) DC current (mA), DC current standard signal (4-20 mA) Scan interval: 100/200/500 ms, 1/2/5 s Power consumption: 0.7 W
-L1	Low withstand voltage DCV/TC/DI, scanner type (isolation between channels) DC voltage, standard signal, thermocouple, DI (voltage, contact), DC current (when an external shunt resistor is connected) Scan interval: 500 ms, 1/2/5 s Power consumption: 0.7 W
-T1	DCV/TC/DI, electromagnetic relay scanner type (isolation between channels) DC voltage, standard signal, thermocouple, DI (voltage, contact), DC current (when an external shunt resistor is connected) Scan interval: 1/2/5 s Power consumption: 0.9 W
GX90XD	Digital input module (number of inputs: 16) A module that can receive open collector or voltage-free contact signals. Scan interval: 100/200/500 ms, 1/2/5 s Power consumption: 0.7 W
GX90YD	Digital output module (number of outputs: 6) A module that can transmit relay contact (c contact) signals. Scan interval: 100/200/500 ms, 1/2/5 s Power consumption: 1.4 W
GX90WD	Digital I/O module (number of inputs: 8, number of outputs: 6) A module that can receive open collector or voltage-free contact signals and transmit relay contact (c contact) signals. Scan interval: 100/200/500 ms, 1/2/5 s Power consumption: 1.6 W

Continues on the next page

Model	Description
GX90XP	Pulse input module (number of inputs: 10) A module that can receive open collector, voltage-free contact, or 5 V logic signals. Scan interval: 100/200/500 ms, 1/2/5 s Power consumption: 0.9 W

For the detailed specifications of the I/O modules, see the following general specifications.

Material No.: GS 04L53B01-01EN

### • System Configuration

SMARTDAC+ GM supports both standalone operation and data acquisition using a PC.

#### Single Unit System

A system configured with only a main unit.

##### Use as a stand-alone type



##### Use by connecting a PC

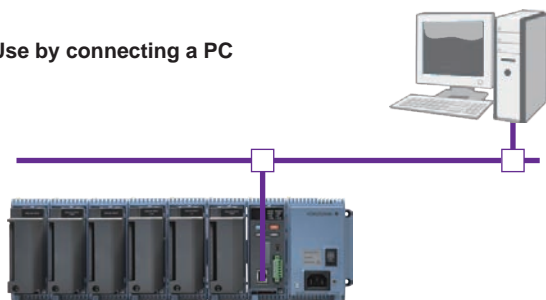

#### Multi Unit System

A system configured with a main unit connected to sub units.

- Up to six sub units can be connected to a main unit. Each unit can connect up to six modules.
- For analog input, up to 420 channels (GM10-2) and up to 100 channels (GM10-1) can be measured.

##### Use as a stand-alone type

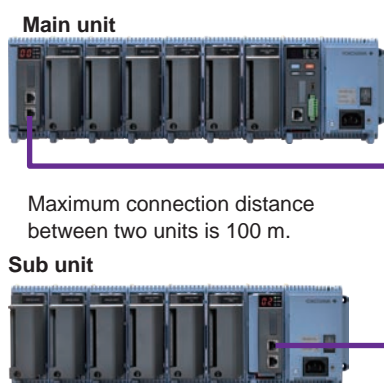

#### Use by connecting a PC



\* The main unit and sub units are connected using LAN cables.

#### Module connection limitations

- If a GX90XA analog input module (electromagnetic relay type: -T1) is connected, the main unit (single unit system) can connect up to eight I/O modules.
- If you want to use reference junction compensation on a thermocouple input of a GX90XA analog input module, do not install the following module to the right of the GX90XA as seen from the front. Doing so may cause the reference junction compensation accuracy to deviate from the guaranteed range. GX90XA-10-C1 (for mA) or GX90WD
- Up to a total of 10 GX90YD digital output modules and GX90WD digital I/O modules can be connected in each system.
- One GX90WD digital I/O module can be installed in each unit.

## ■ SMARTDAC+ GM COMMON SPECIFICATIONS

### ● Compliant Standards

- CSA: CSA22.2 No.61010-1, installation category II<sup>\*1</sup>, pollution degree 2<sup>\*2</sup>, CSA C22.2 NO. 61010-2-030-12
- UL: UL61010-1, UL 61010-2-030(CSA NRTL/C)

#### • CE:

EMC directive:

- EN61326-1 compliance, Class A Table 2
- EN61000-3-2 compliance
- EN61000-3-3 compliance
- EN55011 Class A Group 1

Low voltage directive:

- EN61010-1, EN 61010-2-030
- Installation category II<sup>\*1</sup>, pollution degree 2<sup>\*2</sup>
- Measurement category II<sup>\*3</sup>

/C8 option

R&TTE directive:

HEALTH&SAFETY

- EN61010-1 compliance
- EN61010-2-030 compliance
- Installation category II<sup>\*1</sup>, pollution degree 2<sup>\*2</sup>
- Measurement category II<sup>\*3</sup>
- EN62311 compliance

EMC

- EN301 489-1 compliance
- EN301 489-17 compliance
- EN61326-1 compliance

SPECTRUM

- EN300 328 compliance

- EMC Regulatory Arrangement in Australia and New Zealand (RCM):
  - EN55011 compliance, Class A Group 1
- Wireless communication standards of Australia and New Zealand (RCM) (optional code /C8):
  - AS/NZS4268, AS/NZS2772.2
- KC marking: Electromagnetic wave interference prevention standard, electromagnetic wave protection standard compliance
- Wireless module certification and the like:
  - FCC Approval, IC Approval, Japanese Radio Law
  - Korea Certification (Radio Wave Act),
  - China Certification (Radio Wave Act)

\*1 Installation category (overvoltage category) II: Describes a number which defines a transient overvoltage condition. Implies the regulation for impulse withstand voltage. "II" applies to electrical equipment which is supplied from the fixed installation like a distribution board.

\*2 Pollution degree 2: Describes the degree to which a solid, liquid, or gas which deteriorates dielectric strength or surface resistivity is adhering. "2" applies to normal indoor atmosphere. Normally, only non-conductive pollution occurs.

\*3 Measurement category: Depends on the specification of each modules

Category	Measurement category	Description	Remarks
II	CAT II	Available in the testing and measuring circuits directly connected to a usage location (receptacle or the like) of a low-voltage main power supply facility.	Appliances, portable equipment, etc.

Category	Measurement category	Description	Remarks
III	CAT III	Available in the testing and measuring circuits connected to a power distribution portion of a low-voltage main power supply facility.	Distribution board, circuit breaker, etc.
IV	CAT IV	Available in the testing and measuring circuits connected to a power source of a low-voltage main power supply facility.	Overhead wire, cable systems, etc.

- WEEE Directive: Compliant

### ● Normal Operating Conditions

- Rated supply voltage:
  - 100 to 240 V AC (AC power supply) or
  - 12 to 28 V DC (DC power supply)
- Allowable supply voltage:
  - 90 to 264 V AC (AC power supply) or
  - 10 to 32 V DC (DC power supply)
- Power frequency (AC power supply):
  - 50 Hz  $\pm 2\%$ , 60 Hz  $\pm 2\%$
- Power consumption:

Supply voltage	Normal operation*	Maximum
100 V AC	25 VA	45 VA
240 V AC	35 VA	60 VA
12 V DC	15 VA	24 VA
28 V DC		

\* When 10 analog input modules are connected

- Ambient temperature:  $-20$  to  $60$  °C
  - $-20$  to  $50$  °C in the following cases
    - When a GX90YD is used
    - When a GX90WD is used
    - When a GX90XA-T1 (electromagnetic relay type) is used
  - On a GM10 with the /C8 option
- Ambient humidity: 20 to 85 %RH (no condensation)
- Magnetic field: 400 A/m or less (DC and 50/60 Hz)
- Vibration:  $5 \leq f < 8.4$  Hz amplitude 3.5 mm (peak)  
 $8.4 \leq f \leq 160$  Hz acceleration 9.8 m/s<sup>2</sup> or less
- Shock:
  - Power supply ON, 98 m/s<sup>2</sup> or less, 11 ms (excluding GX90YD and GX90WD)
  - Power supply OFF, 500 m/s<sup>2</sup> or less, approx. 10 ms
  - 6 directions ( $\pm X$ ,  $\pm Y$ ,  $\pm Z$ ), 3 times in each direction
- Mounting position: Left and right horizontal, front and back horizontal
- Altitude: 2000 m or less
- Installation location: Indoors
- Warm-up time: At least 30 minutes after power on

### ● Transport and Storage Conditions

- Ambient temperature:  $-25$  to  $70$  °C
- Ambient humidity: 5 to 95 %RH (no condensation)
- Vibration: 10 to 60 Hz, 4.9 m/s<sup>2</sup> maximum
- Shock: 392 m/s<sup>2</sup> maximum (in packaged condition)

### ● Construction

Mounting: Wall mount, DIN rail (panel storage, rack), desktop

Note: No stacking

Material: Polycarbonate

## GM10 DATA ACQUISITION MODULE SPECIFICATIONS

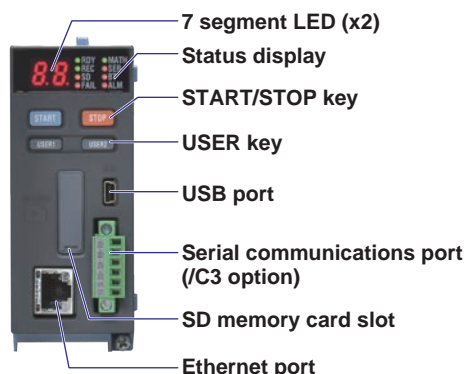

7 segment LED: Displays the operation mode, system No., self-check operation, key lock, operation error, process running, and module installation information.

Status display:

Item	LED color	Description
RDY	Green	System normal indication
REC	Green	Recording status
SD	Orange	SD card access status
FAIL	Red	System error indication
MATH	Green	Computation status
SER	Orange	Serial communication status
BT	Orange	Bluetooth communication status
ALM	Red	Alarm status

START key: Starts recording and computation

STOP key: Stops recording and computation, clears errors

USER keys (USER1/USER2):

Executes specified actions (event action function)

### Functional Specifications

#### Measuring Function

Number of connectable modules and number of I/O channels:

##### GM10-1

Modules	I/O channels
Up to 10	Up to 100

##### GM10-2

Modules	I/O channels
Up to 42	Up to 500 (up to 420 if AI only)

Scan interval: Selectable from 100 ms, 200 ms, 500 ms, 1 s, 2 s, 5 s

Note: Some intervals will be unavailable depending on the system configuration and modules.

#### Module connection limitations

- The maximum number of connectable sub units is six.
- If the maximum number of I/O channels are assigned and the last channel is assigned to an intermediate channel of a connected I/O module, that module and subsequent modules will not be recognized.

#### GM10-1

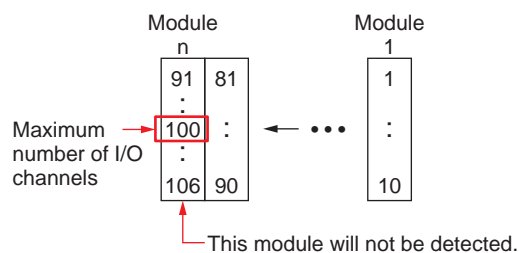

#### Channel Specifications

Operations such as measurement, computation, and recording are performed on channels.

- Channel name: A channel name is expressed with a 4-digit number. Channel names are specific to the system, so they cannot be changed. By setting tags or tag numbers to the channels, you can use any names you like.

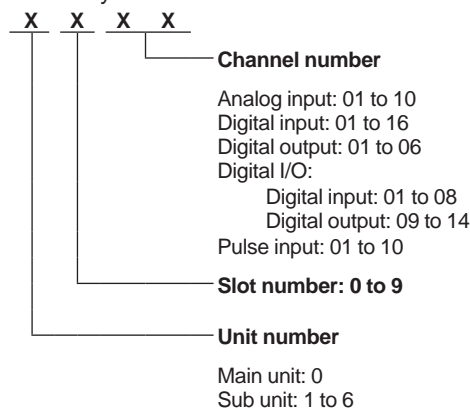

#### Display Function

Real-time data monitoring is possible using a Web browser.

- Number of groups: GM10-1: 50, GM10-2: 60
- Number of channels that can be assigned to each group: 20
- Display types: Trend, digital, bar graph, horizontal bar graph, overview, alarm summary, message summary, DO channel status, internal switch status, Modbus master status, Modbus client status, WT client status, SLMP client status, memory data list, report data list, manual sampled data list, various error logs, network information, system information

Display update interval: Minimum 1 second

## Data Saving Function

Data is recorded to internal memory and external storage medium. When the system recovers from a power failure, the operation that was being performed before the power failure is resumed.

- Internal memory: Temporarily saves various types of data.

Medium: Flash memory  
Size: GM10-1: 500 MB  
GM10-2: 1.2 GB

- External storage medium:

Medium: SD card (SD/SDHC)  
Size: 1 to 32 GB (1 GB included)  
Format: FAT32 or FAT16

Data saving to the external storage medium:

Select whether to save automatically or when a medium is inserted for event data, display data, manual sampled data, and report data.

Auto save: Automatically saves to the internal memory when a data files is created.

Save when a medium is inserted:

Saves unsaved data files when an external storage medium is inserted.

- Data type:

Data type	Saved content
Display data	Maximum and minimum values per recording interval
Event data	Instantaneous values at recording intervals
Alarm summary data	Summary of warnings
Manual sampled data	Instantaneous values at a user specified time
Setup data	GM10 and I/O module settings
Report data (/MT option)	Report at each scheduled time of report

- Event data:

Target: Measurement (I/O module)/math (/MT)/ communication (/MC) channels, alarm summary, message summary

Recording interval: 100 ms/200 ms/500 ms/1 s/2 s/5 s/10 s/15 s/20 s/30 s/1 min/2 min/5 min/10 min/15 min/20 min/30 min selectable

Note: Some intervals will be unavailable depending on the scan interval and number of channels.

Number of channels: Determined by the scan interval and recording data type

### GM10-1

Recording interval	Number of channels
100 ms	100
200 ms	200
500 ms or longer	500

### GM10-2

Recording interval	Number of channels	
	Event	Display + Event
100 ms	500	100
200 ms	500	200
500 ms	1000	500
1 s or longer	1000	1000

Data size:

Analog input data: 6 bytes/ch.

Digital I/O data: 2 bytes/ch.

Math channel data: 6 bytes/ch.

Communication channel data: 6 bytes/ch.

File size: Up to 18 MB

Number of files (including display data)

GM10-1: Up to 500

GM10-2: Up to 1000

Internal memory operation: FIFO (First In First Out)

Data format: Binary or text

Mode:

Free: Records data at all times

Trigger: Starts recording data when a certain event occurs and records for the specified interval

Repetition trigger: Repeat Trigger mode

Event data file sample time (estimated)

GM10-1 (when recording interval is 1 s)

I/O channels	Total sample time
30	Approx. 29 days
100	Approx. 9 days

GM10-2 (when recording interval is 1 s)

I/O channels	Total sample time
30	Approx. 71 days
100	Approx. 23 days
300	Approx. 7 days

- Display data:

Target: Measurement (I/O module)/math (/MT)/ communication (/MC) channels, alarm summary, message summary

Trend interval (/div) (recording interval): 5 s/10 s/15 s/20 s/30 s/1 min/2 min/5 min/10 min/15 min/20 min/30 min selectable

Note: Some intervals will be unavailable depending on the scan interval and number of channels.

Number of channels: Determined by the trend interval and recording data type

### GM10-1

Trend interval setting (/div)	Recording interval	Number of channels
5 s	100 ms	100
10 s	200 ms	200
15 s or longer	500 ms or more	500

### GM10-2

Trend interval setting (/div)	Recording interval	Number of channels	
		category	Display + Event
5 s	100 ms	200	100
10 s	200 ms	500	200
15 s	500 ms	1000	500
30 s or longer	1 s or longer	1000	1000

Data size:

Analog input data: 12 bytes/ch.

Digital I/O data: 4 bytes/ch.

Math channel data: 12 bytes/ch.

Communication channel data: 12 bytes/ch.

File size: Up to 18 MB

Number of files (including event data)

GM10-1: Up to 500

GM10-2: Up to 1000

Internal memory operation: FIFO(First In First Out)

Data format: Binary or text

Display data file sample time (estimated)

**GM10-1 (when recording interval is 1 min)**

I/O channels	Total sample time
30	Approx. 914 days (2.5 years)
100	Approx. 239 days (9 months)

**GM10-2 (when recording interval is 1 min)**

I/O channels	Total sample time
30	Approx. 2184 days (5.9 years)
100	Approx. 702 days (1.9 years)
300	Approx. 239 days (7 months)

- Alarm summary:
  - Saved item: Alarm of each data item
  - Maximum number of items saved to internal memory: 5000
  - Internal memory operation: FIFO(First In First Out)
  - Maximum number of items displayed on Web screen: Latest 1000
  - Save operation: Saves alarm information to internal memory when an alarm occurrence or release is detected
  - \* Alarm information is saved to the corresponding event or display data file.
  - Saved content: Target channel name (tag name), time of occurrence or release, warning type, etc.
  - Save operation methods: Web browser, communication command
- Message summary:
  - Description: Saves a summary of written messages
  - Saved item: Message string
  - Maximum number of items saved to internal memory: 1000
  - Internal memory operation: FIFO (First In First Out)
  - Maximum number of items displayed on Web screen: Latest 450
  - Save operation: Saves message information to internal memory when message writing operation is performed.
  - \* Message information is saved to the corresponding display or event data file.
  - Saved content: Message name, writing interval, user name, write group
- Manual sampled data:
  - Saved item: Measurement (I/O module)/math (/MT)/communication (/MC) channels
  - Number of saved channels:
    - GM10-1: Up to 50, GM10-2: Up to 100
  - Save operation methods: Web browser, communication command, event action
  - Maximum number of events saved to internal memory: 400
  - Internal memory operation: FIFO (First In First Out)
  - Auto saving to an external storage medium: Every time manual sampling is executed
  - Data format: Text format
- Setup data
  - Saved item: GM10 and I/O module settings (including setup data of modules connected via GX90EX)
  - Saved events: Operation from a Web browser, communication command, event action, setting changes (when the advanced security function (/AS) is on)
  - Data format: Text format
    - Binary format when the advanced security function (/AS) is on

- Report data (/MT option):
  - Saved item: Measurement (I/O module)/math/communication channels
  - Select from average, maximum, minimum, sum, and instantaneous values
  - Type: Hourly + daily, daily + weekly, daily + monthly
    - User specified time (batch, day custom)
  - Saved events: Timeout time of each report type
  - Maximum number of events saved to internal memory: 800
  - Internal memory operation: FIFO (First In First Out)
  - Auto saving to an external storage medium:
    - Save every time of the event
  - Data format: Test format
- User data
  - Saved item: Excel report template (/MT), PDF/print report template, SSL communication certificate (server certificate, trusted certificate), electronic signature certificate (/MT)
  - Recorded events: Operation from a Web browser, communication command

### Message Write Function

Messages can be written to event data and display data.

- Message type:
  - Preset message: Writes preset text
  - Free message: Writes text that you enter
  - Auto message: Writes fixed text when power recovers after a power failure occurs during recording.
- Preset message, free message:
  - Number of displayable characters: Up to 32
  - Displayable character types: Alphanumeric, Japanese, and Chinese characters
  - Number of messages: Preset message: 100  
Free message: 10
  - Free messages that you enter are also saved in setup files.
- Write method: Operation from a Web browser, communication command, event action
- Write destination: Specified event data or display data group or all groups
- Auto message
  - Displayed text: "Power-fail" + the time of failure occurrence
  - Example: Power-fail 2014/01/06 09:49:21
  - Write method: Writes a message when power recovers after a power failure occurs during recording.
  - Whether or not to write is selectable.
  - Write destination: All display data or event data groups

### Alarm Function

- Number of alarms: Up to four alarms (levels) for each measurement channel
- Alarm type: High limit, low limit, difference high limit, difference low limit, high limit on rate-of-change, low limit on rate-of-change, delay high limit, and delay low limit
- Alarm delay time: 1 s to 24 hours (for each channel)
- Rate-of-change calculation interval of rate-of-change alarms: 1 to 32 times the scan interval (common to all channels)
- Hysteresis: 0.0 to 5.0% of the span (for each alarm (level))
- Alarm output:  
DO output:  
DO operation: Energize/de-energize, hold/nonhold, AND/OR, reflash  
Internal switch output:  
Number of internal switches: 100  
Internal switch operation: AND/OR operation selectable
- Status LED display operation: Select whether or not to hold the indication until an alarm acknowledge operation is performed
- Alarm no logging function: Possible to output only to the DO or internal switch when an alarm occurs (warning display and recording to the alarm summary are not performed)
- Alarm information: Displays a log of alarm occurrences on the alarm summary
- Reflash: The duration for which the reflash relays are deactivated can be set to 500 ms, 1 s, or 2 s.
- Individual alarm ACK function: Alarm display and relay output can be canceled on individual alarms.

### Event Action Function

- Description: Execute a specified operation when a given event occurs.
- Number of settings: 50  
Events: Remote control input, etc.  
Timer: Number of timers: 12  
Match time timer: Number of timers: 12  
Action: Specify memory start/stop, alarm ACK, etc.

### Security Function

- Key lock function: All GM10 key operations
- Login function: Only registered users can operate the GM (Ethernet /serial (/C3) /USB/Bluetooth (/ C8) operation) (including Web browsers)  
System administrators and users: Up to 50  
Number of Authority of user: 10 levels

### Manual Sampling Function

- Description: Measured value at a user specified time
- Target: Measurement (I/O module)/math (/MT)/communication (/MC) channels
- Number of recording channels:  
GM10-1: Up to 50  
GM10-2: Up to 100
- Maximum number of data values that the internal memory can store: 400
- Data format: Text

### Report Function (/MT option)

- Description: Report at each scheduled time of report
- Target: Measurement (I/O module)/math/communication channels
- Number of report channels: 60

- Maximum number of data values that the internal memory can store: 800
- Data format: Text

### Setup Function

- Description: GM10 and I/O module setup
- Setup method: Web browser, communication commands, Hardware Configurator
- Output/read destination (for saving/loading): External storage medium

### Clock Function

- Clock: With a calendar function  
Accuracy:  $\pm 5$  ppm  
Excludes the delay (of 1 second, maximum) caused when the power is turned on.
- Time difference between units:  $\pm 2$  ms max. (time difference between a sub unit and main unit)
- Time setting: Using Web operation, communication commands, event action, or SNTP client function
- Time adjustment method:  
Limit in which the time is gradually adjusted: Select from the available settings between 5 s and 15 s.  
Whether to change an out-of-limit operation immediately or report it as an error can be selected.  
While memory sampling:  
Corrects the time by 1 ms for each second.  
While memory is stopped:  
Immediately change the time.
- Time zone: Sets the time difference from GMT
- Date format: Select "YYYY/MM/DD", "MM/DD/YYYY", "DD/MM/YYYY" or "DD.MM.YYYY".  
MM expression can be selected from the numeric character or ellipsis. Ex. January: 01 or Jan  
The delimiter can be selected from "/", ".", "\_", "-".

### Ethernet Communication Function

- Electrical specifications: Conforms to IEEE 802.3
- Connection: Ethernet (10BASE-T/100BASE-TX)
- Max. segment length: 100 m
- Max. connecting configuration:  
Cascade Max. 4 level (10BASE-T), Max. 2 level (100BASE-TX)
- Connector: RJ-45
- Protocols: TCP, UDP, IP, ICMP, ARP, DHCP, HTTP, FTP, SMTP, SNTP, Modbus, dedicated protocols, and DARWIN compatible communication
- E-mail client: Automatically sends e-mail at specified times  
E-mail is sent by events as below.
  - Alarm occurring/alarm canceling
  - Recover from power failure
  - Report data generating
  - Storage medium error, FTP client function error
  - Specified time period
- Supported authentication methods:  
POP before SMTP, SMTP authentication (Login, Plain, CRAM-MD5)

- FTP client: Automatically transfers data files to the FTP server  
Applicable files: Event data, display data, report data, etc.
- FTP server: Transfers files, delete files, manipulate directories, and outputs file lists  
Max. number of the simultaneous connections: 4
- Web server: GM10 real-time monitoring and setting changes/operations can be performed from a Web browser.  
Max. number of the simultaneous connections: 4
- SNMP client: Inquires the time to the SNMP server and sets the GM10
- SNMP server: Outputs the GM10 time.  
Time resolution: 5 ms
- DHCP client: Automatically obtains the network address settings from the DHCP server
- Modbus client: Reads data from another device and writes to the registers (Required /MC option)  
Number of connectable servers:  
GM10-1: Up to 16  
GM10-2: Up to 32
- Modbus server: Loads measurement and math channel data  
Loads and writes communication channel data  
Some control commands such as memory start  
Filtering to accept connections only from specific IP addresses available  
Max. number of the simultaneous connections: 4
- Setting/Measurement server:  
Operate and set the GM10 and output data using a dedicated protocol.  
Max. number of the simultaneous connections: 4
- DARWIN compatible communication server:  
Supports some DARWIN commands  
Communication with the GM10 is possible using DARWIN communication commands.  
Output-related commands: Outputs measurement channel data, math channel data, relay status, decimal place of measurement channels, decimal place of math channels, system configuration information  
Setup-related commands: Range, Scale unit, Alarm, Time, Moving average  
Operation-related commands: Reset alarm, Reset timer, Start MATH calculation, Rebuild system, Initialize, Input communication, Output communication DO, Write message  
Note: To control the GM using the DARWIN compatible communication function, you must configure the GM (module type, channel numbers (unit numbers and slot numbers)) to match DARWIN.

#### Batch Function

- Function: Data management using batch names.  
Enter text fields and batch comments in the data file.
- Batch name: Added to the file name of the event data and display data.  
Structure: Batch number (up to 32 characters) + lot number (up to 8 digits)  
Use/not use selectable for lot number, on/off selectable for auto increment function.

- Text field: Adds text to the event data and display data. There are 24 available text fields.  
Title: Up to 20 characters  
Text: Up to 30 characters per field
- Batch comment: Adds text to the event data and display data. 3 comments (max. 50 characters/comments) are available.

#### USB Communication Function

- Compliant standard: USB2.0
- Interface:  
Connector: mini B type  
Number of ports: 1  
Power supply: Self powered
- Implemented protocol: Dedicated protocol  
Operate and set the GM10 and output data using a dedicated protocol.
- Communication conditions:  
Baud rate: 115200bps, Parity: None, Data length: 8bit, Stop bit: 1bit, Handshake: Off

#### FAIL Output Function

- Function: Relay output from a specified channel of the GX90YD or GX90WD when a CPU error occurs
- Output format: Relay contact
- FAIL output: Relay contact output when any of the various errors is detected  
Normally energized; de-energized when a system error occurs

#### Printer Output Function

- Printers supporting the HP PCL5c language and can print through port 9100 on a LAN connection  
Supports printing using the report template function (/MT).

#### SSL Communication Function

- Communication that sends and receives information encrypted by the SSL (Secure Socket Layer) protocol is possible.
- Server function:  
Supported servers: HTTP server and FTP server  
Private key: Can be created on the GM10  
Server certificate: Server certificates created by users can be saved in the internal memory.  
Self-signed certificates can be created on the GM10.
- Client function:  
Supported clients: FTP client and SMTP client  
Trusted certificate: Trusted certificates (up to 80 KB total) can be saved in the internal memory.

#### Electronic Signature Function

- Electronic signatures can be added to report files created in PDF format using the PDF form creation function. An electronic signature is provided each time a report file is created.
- Electronic signature certificate:  
Electronic signature certificates created by certificate issuing organizations can be saved in the internal memory.

#### Other Function

- Firmware update function:  
The firmware of the GM10 and connected modules can be updated from the GM10.
- A/D calibration function:  
The A/D calibration of connected modules can be operated from the GM10.

## Web Server Function

Real-time data monitoring and setting changes/operations can be performed from a Web browser.

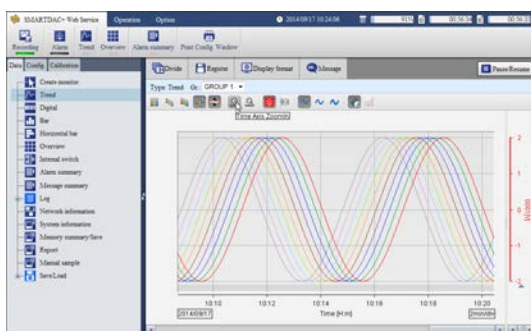
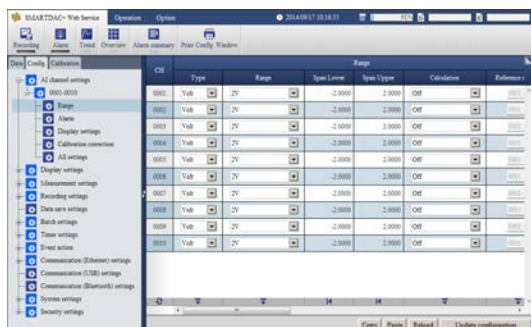

## PC System Requirements

### Hardware

Item	Specifications
CPU	Intel Pentium IV, 3GHz or faster x64 or x86 processor
Internal memory	2 GB or more
Hard disk	100 MB or more free space, NTFS recommended
Printer	Printer compatible with the OS
Mouse	Mouse compatible with the OS
Display	Display compatible with the OS with 1024x768 dots or better, high color or better
Communication port	Ethernet port compatible with the OS and TCP/IP protocol

### OS

Item	Specifications
Windows Vista	Home Premium SP2 (excluding 64-bit editions) Business SP2 (excluding 64-bit editions)
Windows 7	Home Premium SP1 (32-bit edition and 64-bit editions) Professional SP1 (32-bit edition and 64-bit editions)
Windows 8.1	Update (32-bit edition and 64-bit editions) Pro Update (32-bit edition and 64-bit editions)
Windows 10	Home (32-bit edition and 64-bit editions) Pro (32-bit edition and 64-bit editions)

## Compatible Browsers

Internet Explorer 8, Internet Explorer 9, Internet Explorer 10, Internet Explorer 11  
HTTP1.1 and JavaScript are used.

## Software

Java Runtime Environment 1.8.0\_xx (Version 8 Update xx), where xx is 51 or higher

## Specifications of Options

### Advanced Security Function (IAS)

Security and electronic record/signature functions have been added that are compliant with the USA's FDA title 21 CFR Part 11.

- Enabling/disabling the advanced security function:  
You can enable or disable the advanced security function.  
\* The set values and data stored in the internal memory are initialized each time the function is enabled or disabled.
- Login function: Using the login function described below, you can enter security settings on the instrument  
User name, password, and user ID (depending on the use/not use setting)

#### User level:

Administrator: No restrictions (all operations)  
User: Operations that can be executed can be set using the authority of user settings.

Monitor user: Only monitoring and changing passwords are possible.

Number of users: Up to 100 including administrators, users, and monitor users

Authority of user: Users can be restricted from performing GM operations.

Number of authority of user: 10

Password expiration period: Off, 1 month, 3 months, or 6 months (no expiration period for monitor users)

Signature restriction: Users can be restricted from signing measurement data files.

Number of signature restrictions: 8

- Password control function: Logins are verified by a Kerberos v5 authentication server\* (only user name and password)

#### Encryption method:

AES128-CTS-HMAC-SHA1-96

AES256-CTS-HMAC-SHA1-96

ARCFOUR-HMAC-MD5

Pre-Auth function: use

\* The function has confirmed compatibility with Windows Server2003 SP2/Windows Server2008 SP2/Windows Server2012 ActiveDirectory

- Audit trail function: The history of operations from when the recording was stopped the previous time to when the recording was stopped this time is recorded as event log and saved in measurement data files along with the settings.
- Data anti-tamper function: Settings and measured data are saved as encrypted binary files.
- Data type: Only for display or event  
Trigger mode is not possible with event data.
- Signature function\*: Includes approval information to measurement data files  
Information that can be included: User name, pass/fail, comment  
Number of signatures: Up to 3 per file  
Signature privileges: Can be set for each user  
\* Universal Viewer is used to sign measurement data.  
• Signing measurement data files is not possible from the GM10.

### Serial Communication Interface (IC3)

- Connection: EIA RS-422/485
- Protocol: Dedicated protocol, Modbus/RTU, or DARWIN compatible communication
- Setting/measurement server function:  
Operation, setting or output of measurement data are available by dedicated protocol.
- Synchronization: Start-stop synchronization
- Transmission mode (RS-422/485):  
RS-422: Four-wire half-duplex multi-drop connection (1:n (n = 1 to 31))  
RS-485: Two-wire half-duplex multi-drop connection (1:n (n = 1 to 31))
- Baud rate: 1200, 2400, 4800, 9600, 19200, 38400, 57600, or 115200 bps
- Data length: 7 or 8 bits
- Start bit: 1 bit
- Stop bit: 1 bit or 2 bit
- Parity: ODD, EVEN, or NONE
- Communication distance:  
1200 m (57600 bps or less), 600 m (115200 bps)
- Modbus/RTU communication:  
Reading or writing of measurement data on other instruments is available by Modbus protocol.  
Communication channel function (/MC option) is needed to read measurement data from other instruments.
- Modbus operation modes: Master or slave

### Bluetooth Communication Function (IC8)\*

- Data monitoring, setting, and operation is possible on a tablet, such as a Bluetooth compatible PC or smartphone, through Bluetooth communication.
- Compliant standard: Bluetooth Ver 2.1+EDR
  - Supported profile: SPP (Serial Port Profile)
  - Carrier frequency band: 2402 to 2480 MHz
  - Channel spacing: 1 MHz
  - Number of channels: 79
  - Communication distance: Approx. 10 m (depends on the operating environment) (Class2)
  - Protocol: Dedicated protocol  
Operate and set the GM10 and output data using a dedicated protocol.
  - Pairing: Maximum number of connections 8 (multi pairing)  
Overwritten through FIFO when 8 units are exceeded  
Displays the 6-digit SSP (Secure Simple Pairing) authentication code and checks for a match (numeric comparison)
  - Password request function: Requests connected terminals for passwords
    - \* Regions in which Bluetooth can be used are restricted by the Radio Waves Act of each country. For details, contact the appropriate authority.

### Mathematical Functions with Report Function (/MT)

#### Mathematical Function:

- Number of math channels: GM10-1: 100, GM10-2: 200
- Operations:  
General arithmetic operations: Four arithmetic operations (+, -, \*, /), square root, absolute, common logarithm, natural logarithm, exponential, and power  
Relational operations: <, ≤, >, ≥, =, and ≠  
Logic operations: AND, OR, NOT, and XOR

Statistical operations: TLOG (maximum, minimum, average, sum, P-P values of time series data), CLOG (maximum, minimum, average, sum, P-P values of a specified channel)

Special operations: PRE, HOLD, RESET, CARRY

Conditional operation: [a?b:c]

Bit operation: BIT

Integer extracting operation: INT

Remainder extracting operation: MOD

Trigonometric functions: SIN, COS

- Computation accuracy:  
Double-precision floating point
- Data that can be used  
Channel data:  
Measurement channels: 0001 to 6516  
Math channels: A001 to A100 (GM10-1)  
A001 to A200 (GM10-2)  
Communication channels:  
C001 to C300 (GM10-1)  
C001 to C500 (GM10-2)  
Communication channel raw data:  
RC001 to RC300 (GM10-1)  
RC001 to RC500 (GM10-2)  
Constants: K001 to K100  
Internal switches: S001 to S100  
Flags: F01 to F20  
Recording state: REC01

#### Report function:

- Number of report channels: 60
- Report types: Hourly + daily, daily + weekly, daily + monthly, batch, day custom
- Computation types: Average, maximum, minimum, sum, instantaneous value  
Unit of sum: OFF, /s, /min, /hour, /day
- Report templates: Office Open XML spreadsheet files (which can be displayed with Microsoft Office Excel) or PDF files can be output or printed out with any LAN-connected printer supporting the HP PCL5c language and the port 9100.

#### Communication Channel Function (/MC)

Data of external devices, such as PLC and PC, can be displayed and recorded.

- Number of communication channels:  
GM10-1: 300 (C001 to C300)  
GM10-2: 500 (C001 to C500)

#### Log Scale (/LG)

A logarithmic voltage that has been converted from a physical value is applied to the GM10, and then the GM10's Log scale (logarithmic scale) is used to display and record the physical value.

- Input type: Log input (logarithmic input), pseudo log input (input that supports pseudo logs), log linear input (input that is linear on a logarithmic scale)
- Range: 20mV/60mV/200mV/1V/2V/6V/20V/50V
- Scalable range:  
Log input: 1.00E-15 to 1.00E+15  
(15 decades maximum)  
Scale\_L < Scale\_U  
If the lower limit mantissa is 1.00, the difference between the exponents must be 1 or more.  
If the lower limit mantissa is a value other than 1.00, the difference between the exponents must be 2 or more.

**Pseudo Log Input/Log linear input**

1.00E-15 to 1.00E+15 (15 decades maximum)

The upper limit mantissa is the same as the lower limit mantissa.

If the lower limit mantissa is 1.00, the value must be between 1.00E-15 and 1.00E+15, the difference between the exponents must be 1 or more, and the maximum decades is 15.

If the lower limit mantissa is a value other than 1.00, the value must be between 1.01E-15 and 9.99E+14, the difference between the exponents must be 1 or more and the maximum decades is 15.

- Alarm type: High limit, low limit, delay high limit, delay low limit
- Alarm setting range: The range converted into the LOG scale corresponding to -5% to 105% of the span width.
- Alarm hysteresis: Fixed to 0
- Green band setting range: The lower limit to the upper limit of the scale. However, the lower limit of the display position must be smaller than the upper limit.
- Decimal place: 1 or 2
- Misc: Nonlinear input is possible by correcting the input value.

**EtherNet/IP Communication (PLC communication protocol) (/E1)**

Can join an Ethernet/IP network as an adapter (or a server)

- Loading data from the measurement (I/O module) channel or math channel (/MT)  
I/O channel: GM10-1: 100, GM10-2: 500  
Calculation channel: GM10-1: 100, GM10-2: 200
- Loading and writing data from/to the communication channel (/MC)  
Communication channel:  
GM10-1: 300, GM10-2: 500
- Implementation level: Level 2
- Maximum number of connections: 20 (up to 10 at the TCP/IP level)
- Supported protocols: EIP/PCCC, EIP/native

**WT Communication (/E2)**

Acquires data by connecting to WT equipment manufactured by Yokogawa Meters & Instruments Corp. via Ethernet communication.

- Supported models: WT1800, WT500, WT300
- Number of connectable units: 16
- Communication cycle:  
500 ms/1 s/2 s/5 s/10 s/20 s/30 s
- Types of data that can be obtained: Voltage, current, power, power factor, phase, electrical energy, high-frequency wave, etc.
- Number of data allocations: 300

**Multi-batch Function (/BT)**

Recording start/stop and data file creation is possible for each batch.

- Number of multi batches  
GM10-1: 6 max., GM10-2: 12 max.
- Batch single operation: Memory start/stop, math reset, message writing
- Batch overview operation: Computation start/stop, report start/stop, manual sampling, setup data save/load

- Scan interval: 500 ms, 1 s, 2 s, 5 s (common to all batches)
- Data type: Display or event only Trigger mode not available for event data.
- Recording interval: Common to all batches
- Data file: Display or event data file created for each batch
- Number of display groups:  
GM10-1: 6 max. per batch  
Number of channels per group: 10  
GM10-2: 12 max. per batch  
Number of channels per group: 20  
Channels assigned to the display group of each batch and those set as recording channels are recorded to data files.
- Batch single settings: Group, trip line, file header, data file name, text field, batch number, lot number

**Aerospace Heat Treatment (/AH)**

Supports heat treatment application AMS2750/NADCAP

Schedule management for periodically executing calibration correction configuration and the like  
In correction coefficient mode of calibration correction, two biases can be specified: one based on thermocouple and another based on device

- Number of manageable schedules  
GM10-1: 6 max., GM10-2: 12 max.
- Calibration correction mode: Off, linearizer approximation, linearizer bias, correction coefficient  
Number of set points: 2 to 12

**OPC-UA Server (/E3)**

Data acquired by the GM can be accessed through Ethernet communication from a host system (OPC-UA client).

- Communication  
Type: OPC-UA Server  
Encoding: UA Binary  
Protocol: OPC UA TCP  
Maximum number of connections: 3 sessions  
Profile: Micro Embedded Device Server
- Security  
Mode: None  
Encryption: None  
Login: Anonymous, Username
- Data acquisition:  
Measurement value, alarm status, alarm value  
Computation value, alarm status, alarm value  
Communication value, alarm status, alarm value  
Batch information
- Data writing: Measurement channel (DO channel only), communication channel, alarm value, batch information
- Other acquired information: Device name, serial number, time, device status
- Port number: 4840 (changeable: 1 to 65535)
- Number of items: 300 max. (MonitoredItem/Session)
- Fastest period: 100 ms

- Service set:

Discovery	FindServers, GetEndpoints
SecureChannel	OpenSecureChannel, CloseSecureChannel
Session	CreateSession, ActivateSession, CloseSession
View	Browse, BrowseNext, TranslateBrowsePathsToNodeIds
Attribute	Read, Write
MonitoredItem	CreateMonitoredItems, ModifyMonitoredItems, DeleteMonitoredItems, SetMonitoringMode
Subscription	CreateSubscription, ModifySubscription, DeleteSubscriptions, Publish, Republish, SetPublishingMode

### SLMP Communication (Mitsubishi PLC) (/E4)

Protocol function that enables connection from a GM to Mitsubishi Electric PLCs without sequencer programs.

- Number of connection destination servers: 16 max.
- Read cycle: 100 ms, 200 ms, 500 ms, 1 s, 2 s, 5 s, 10 s, 20 s, 30 s, 1 min
- Communicable internal data:
  - Special relay (SM), special register (SD), input (X), output (Y), internal relay (M), latch relay (L), annunciator (F), edge relay (V), link relay (B), data register (D), link register (W), timer contact (TS), timer coil (TC), current timer value (TN), integration timer contact (SS), integration timer coil (SC), current integration timer value (SN), counter contact (CS), counter coil (CC), current counter value (CN), special link relay (SB), special link register (SW), direct access input (DX), direct access output (DY), index register (Z), file register (R, ZR), extended data register (D), extended link register (W)

Device code is indicated in parentheses.

## GM10 HARDWARE SPECIFICATIONS

- Material: Polycarbonate
- External Dimensions: 45.1(W)×111(H)×107.1(D) mm
- Weight: Approx. 0.25 kg

### Power Supply and Isolation

- Power supply: Supplied from the GM90PS Power Supply Module
- Power consumption: 2.8 W maximum
- Insulation resistance: Between RS-422/485 terminal and internal circuit and between Ethernet terminal and internal circuit, 20 MΩ or higher at 500 V DC
- Isolation diagram

RS-422/485 terminal (/C3 option)	Internal circuit GM90PS ground terminal
Ethernet port	

Circuits delimited by lines are mutually isolated.

### Other Specifications

- Memory backup: A built-in lithium battery backs up the settings and runs the clock.

### External Dimensions

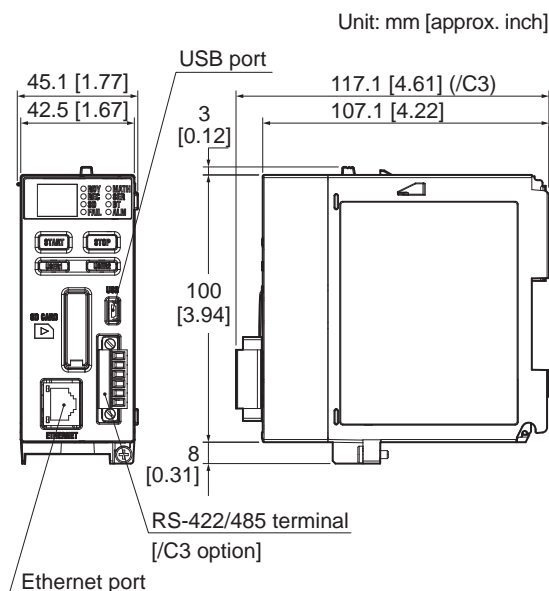

## GM90MB MODULE BASE SPECIFICATIONS

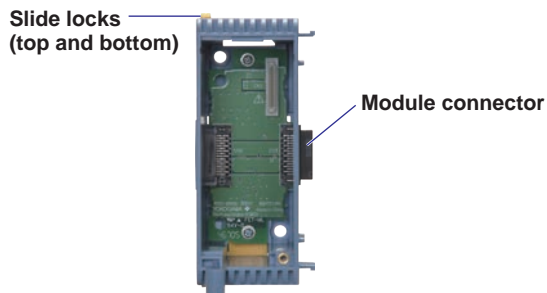

- Number of installable modules: 1
- Power consumption: Less than 0.01 W
- Automatic module number assignment function: Automatically assigns a module number when a module is connected
- External Dimensions: 57.7(W)×135(H)×103.5(D) mm
- Weight: Approx. 0.15 kg

### External Dimensions

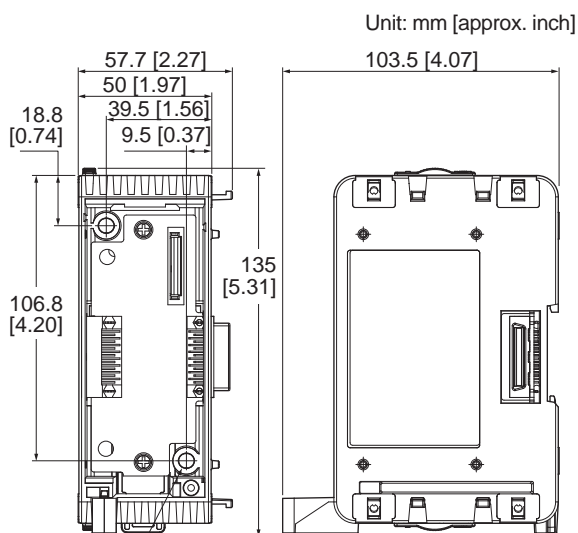

2- $\phi$ 5.5[0.22]×5.9[0.23]  
Oval hole  
for wall mounting

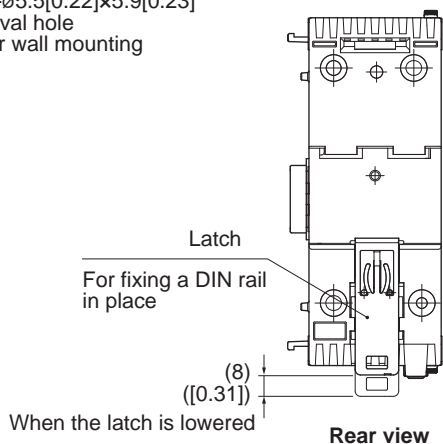

Rear view

## GM90PS POWER SUPPLY MODULE SPECIFICATIONS

Unit: mm

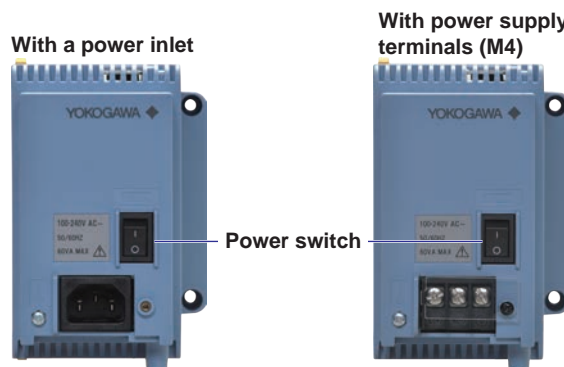

### GM90PS-1N1[0]

- Rated supply voltage: 100 to 240 VAC
- Allowable supply voltage: 90 to 264 V AC
- Power frequency: 50 Hz  $\pm$  2%, 60 Hz  $\pm$  2%
- Power switch: Available
- Terminal type: Inlet or M4 screw terminal
- Allowable interruption time: Less than 1 cycle of the power supply frequency
- Insulation resistance: Between the power supply terminal and earth: 20 M $\Omega$  or higher at 500 V DC
- Withstand voltage: Between the power supply terminal and earth: 3000 V AC (50/60 Hz) for 1 minute
- Grounding: Be sure to set a low grounding resistance.
- Material: Polycarbonate
- External Dimensions: 56.8(W)×135(H)×107.1(D) mm
- Weight: Approx. 0.55kg

### GM90PS-1N2W0

- Rated supply voltage: 12 to 28 V DC
- Allowable supply voltage: 10 to 32 V DC
- Power frequency: 50 Hz  $\pm$  2%, 60 Hz  $\pm$  2%
- Power switch: Available
- Terminal type: M4 screw terminal
- Allowable interruption time: 2 ms or less
- Insulation resistance: Between the power supply terminal and earth: 20 M $\Omega$  or higher at 500 V DC
- Withstand voltage: Between the power supply terminal and earth: 1000 V AC (50/60 Hz) for 1 minute
- Grounding: Be sure to set a low grounding resistance.
- Material: Polycarbonate
- External Dimensions: 56.8(W)×135(H)×107.1(D) mm
- Weight: Approx. 0.55kg

## • External Dimensions

Unit: mm [approx. inch]

### With a power inlet

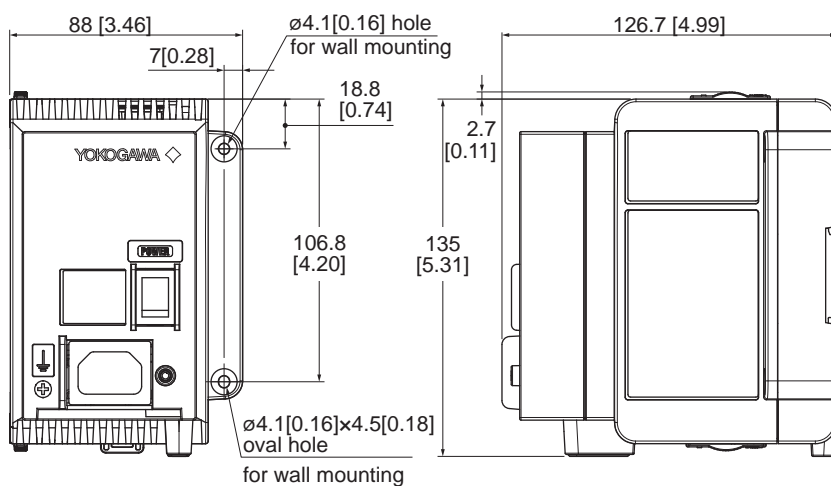

### With power supply terminals (M4)

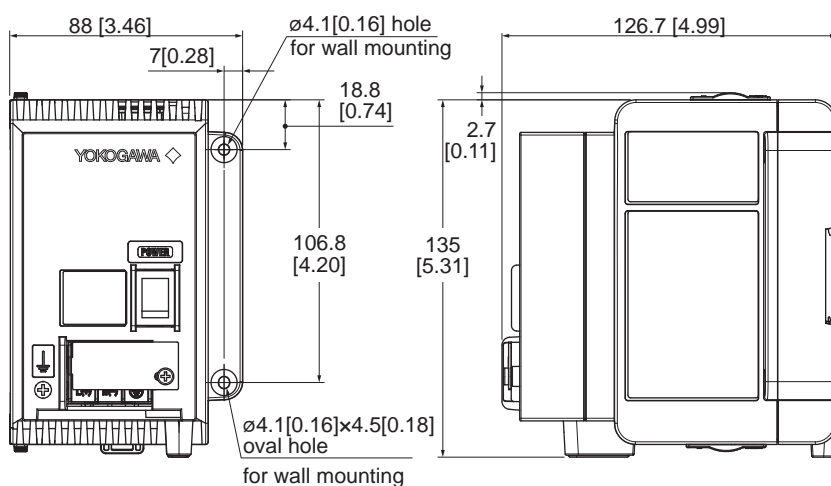

### Rear view

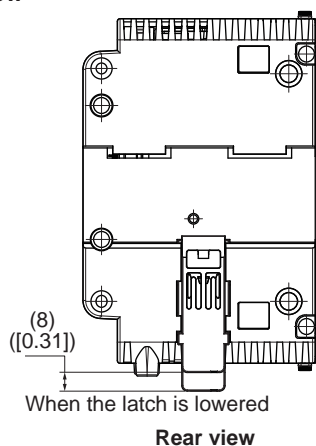

## UNIT EXTERNAL DIMENSIONS

Unit: mm [approx. inch]

### • Main unit (single unit)

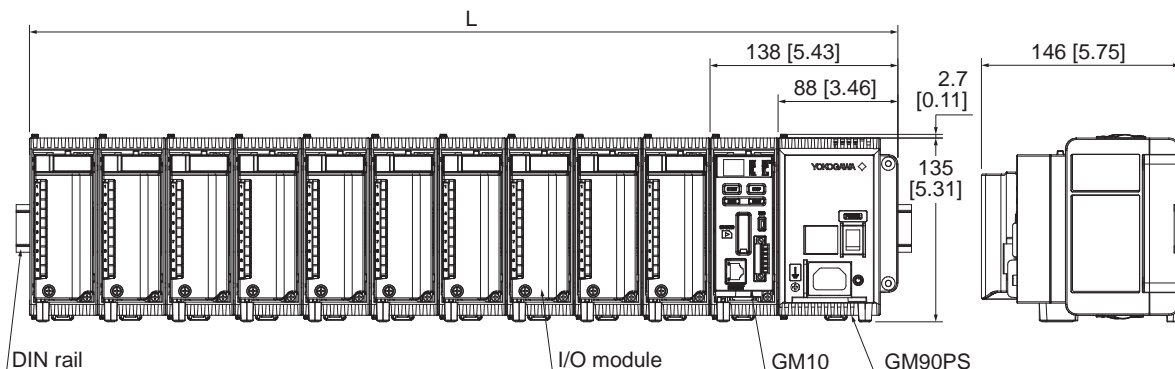

### • Main unit (multi unit)

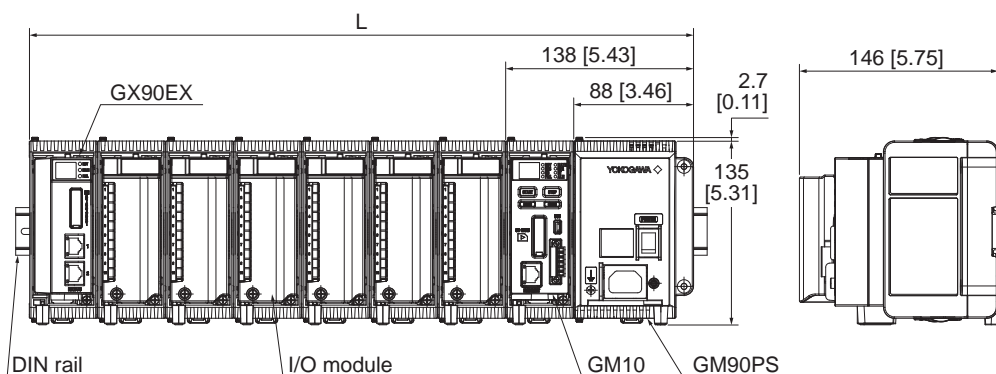

### • Sub unit

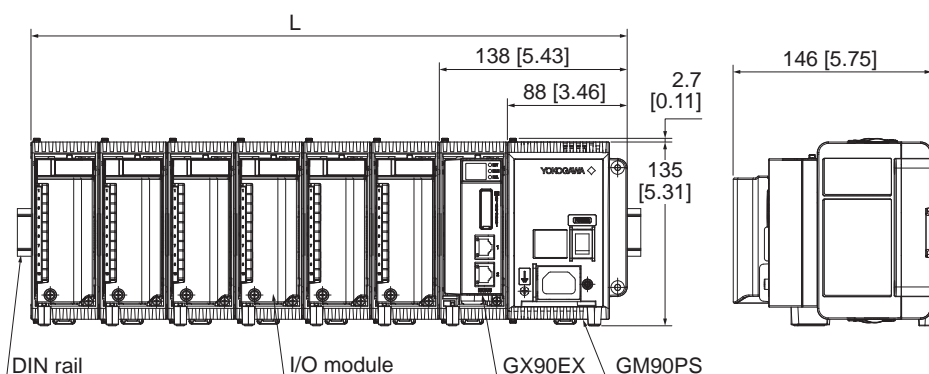

Unit: mm \_\_\_\_\_  
approx. inch

Unit types	Maximum width for each input / output module to be connected: L (mm)										
	0	1	2	3	4	5	6	7	8	9	10
Main unit (single unit)	138	188	238	288	338	388	438	488	538	588	638
	5.43	7.40	9.37	11.34	13.31	15.28	17.24	19.21	21.18	23.15	25.12
Main unit (multi unit)	188	238	288	338	388	438	488				
	7.40	9.37	11.34	13.31	15.28	17.24	19.21				
Sub unit (multi unit)	138	188	238	288	338	388	438				
	5.43	7.40	9.37	11.34	13.31	15.28	17.24				



## APPLICATION SOFTWARE

### SMARTDAC+ STANDARD

- Universal Viewer
- Hardware Configurator
- IP Address Configurator

Download the latest version of the software from the following URL.

[www.smartdacplus.com/software/en/](http://www.smartdacplus.com/software/en/)

### PC System Requirements

#### Operating system:

OS	Type
Windows Vista	Home Premium SP2 (excluding 64-bit editions) Business Edition SP2 (excluding 64-bit editions)
Windows 7	Home Premium SP1 (32- or 64-bit edition) Professional SP1 (32- or 64-bit edition)
Windows 8.1	Update (32- or 64-bit edition) Pro Update (32- or 64-bit edition)
Windows 10	Home (32- or 64-bit edition) Pro (32- or 64-bit edition)

#### Processor and main memory:

OS	Processor and main memory
Windows Vista	Intel Pentium 4, 3 GHz or faster x64 or x86 processor. At least 2 GB.
Windows 7	32-bit edition: Intel Pentium 4, 3 GHz or faster x64 or x86 processor. At least 2 GB.
Windows 8.1	64-bit edition: Intel Pentium 4, 3 GHz or faster x64 processor. At least 2 GB.
Windows 10	64-bit edition: Intel Pentium 4, 3 GHz or faster x64 processor. At least 2 GB.

#### Web browser:

Supported browser: Windows Internet Explorer  
Version: Internet Explorer 8, Internet Explorer 9, Internet Explorer 10, or Internet Explorer 11  
HTTP1.1 and JavaScript are used.

#### Hard disk:

100MB or more of free space (depending on the amount of data, you may need more memory).

#### Display:

A video card that is recommended for the OS and a display that is supported by the OS, has a resolution of 1024 x 768 or higher, and that can show 65,536 colors (16-bit, high color) or more.

#### • Universal Viewer

The universal viewer can display the following data generated by data loggers or recorders on the screen and print it out on the printer.

- Display data file
- Event data file
- Report data file
- Manual sampled data file

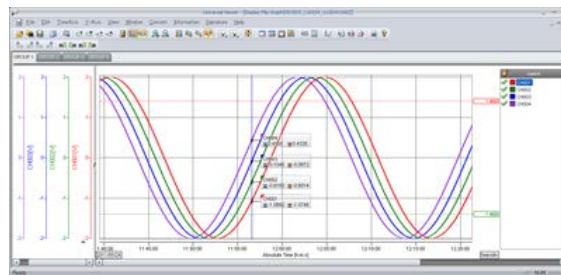

- Viewer function: Waveform display, digital display, circular display, list display, report display, operation log display, etc.
- Data conversion: File conversion to Excel and ASCII format
- Signature function: Signing measurement data files is possible.

#### • Hardware Configurator

- Offline setting on Web browser  
Settings can be configured from Internet Explorer 8, 9, 10, and 11.

ID	Type	Range	Input Level	Input Upper	Calculation	Reference Value
0001	Yield	2%	-2.0000	2.0000	OUT	0001.0
0002	Yield	2%	-2.0000	2.0000	OUT	0001.0
0003	Yield	2%	-2.0000	2.0000	OUT	0001.0
0004	Yield	2%	-2.0000	2.0000	OUT	0001.0
0005	Yield	2%	-2.0000	2.0000	OUT	0001.0
0006	Yield	2%	-2.0000	2.0000	OUT	0001.0
0007	Yield	2%	-2.0000	2.0000	OUT	0001.0
0008	Yield	2%	-2.0000	2.0000	OUT	0001.0
0009	Yield	2%	-2.0000	2.0000	OUT	0001.0
0010	Yield	2%	-2.0000	2.0000	OUT	0001.0

#### • IP Address Configurator

- GM10 IP address assignment  
Edit the GM10's host name, IP address, DNS server, domain name, domain suffix, and so on as well as register the host name to a DNS server.
- GM10 search Search for GMs in the same network segment and list them.

## MODEL AND SUFFIX CODES

### GM10 Model and Suffix Codes

Model	Suffix code	Optional code	Description
<b>GM10</b>			Data Acquisition Module for SMARTDAC+ GM
Type	-1		Standard (Max. measurement channels: 100)
	-2		Large memory (Max. measurement channels: 500)
Area	<b>E</b>		General
—	<b>0</b>		Always zero
Optional features	<b>/AH</b>		Aerospace heat treatment
	<b>/AS</b>		Advanced security function
	<b>/BT</b>		Multi-batch function
	<b>/C3</b>		RS-422/485
	<b>/C8</b>		Bluetooth
	<b>/E1</b>		EtherNet/IP communication (PLC communication protocol)
	<b>/E2</b>		WT communication <sup>*1</sup>
	<b>/E3</b>		OPC-UA sever
	<b>/E4</b>		SLMP communication (Mitsubishi PLC)
	<b>/LG</b>		Log scale
	<b>/MC</b>		Communication channel function
	<b>/MT</b>		Mathematical function (with report function) <sup>*2, *3</sup>

\*1 Communication channel function (/MC option) must be specified at the same time with WT communication.

\*2 Optional code /MT (MATH) required if using the GX90XD's or GX90WD's pulse input.

\*3 Optional code /MT (MATH) required if using the GX90XP's pulse integration.

### GM90PS Model and Suffix Codes

Model	Suffix Code	Description
<b>GM90PS</b>		Power Supply Module for SMARTDAC+ GM
Type	-1	Always -1
Area	<b>N</b>	General
Supply voltage	<b>1</b>	100-240 V AC
	<b>2</b>	12-28 V DC *
Power supply connection	<b>D</b>	Power inlet with UL/CSA cable
	<b>F</b>	Power inlet with VDE cable
	<b>H</b>	Power inlet with GB cable
	<b>N</b>	Power inlet with NBR cable
	<b>Q</b>	Power inlet with BS cable
	<b>R</b>	Power inlet with AS cable
	<b>W</b>	Screw terminal (M4) (without power cable)
—	<b>0</b>	Always zero

\* Only W (Screw terminal (M4)) is available for the power supply connection.

### GM90MB Model and Suffix Codes

Model	Suffix Code	Description
<b>GM90MB</b>		Module Base for SMARTDAC+ GM
—	-01	Always -01
Area	<b>N</b>	General
—	<b>0</b>	Always zero

## ORDERING INFORMATION

Model, suffix code, and optional codes, when necessary, are required to be specified.

\* For modules other than GM90PS (power supply module), a GM90MB (module base) is required for each module.

## STANDARD ACCESSORIES

Model	Standard accessory name	Qty
GM10	SD card (1 GB)	1
GM90PS	Connector cover	1
	Power cable (depends on the suffix code of the power supply connection)	1
	Interconnect screw (M3)	4
GM90MB	Interconnect screw (M3)	4

## OPTIONAL ACCESSORIES (SOLD SEPARATELY)

Product	Model/part no.
SD card (1 GB)	<b>773001</b>
Shunt resistor for M3 terminal (10 Ω ± 0.1 %)	<b>X010-010-3</b>
Shunt resistor for M3 terminal (100 Ω ± 0.1 %)	<b>X010-100-3</b>
Shunt resistor for M3 terminal (250 Ω ± 0.1 %)	<b>X010-250-3</b>
Shunt resistor for clamp terminal (10 Ω ± 0.1 %)	<b>438922</b>
Shunt resistor for clamp terminal (100 Ω ± 0.1 %)	<b>438921</b>
Shunt resistor for clamp terminal (250 Ω ± 0.1 %)	<b>438920</b>
Dummy cover	<b>B8740CZ</b>
Validation Documents (For /AS option) *1	<b>773230</b>

\*1 Provision of Validation Documents A license sheet containing the license key required for installation is provided. Download the validation document from the following URL.  
<http://www.smartdacplus.com/software/en/>

### Related Product (Sold Separately)

Model	Description
GA10	Data Logging Software OS: Windows Vista, Windows 7, Windows 8.1, Windows 10, Windows Server 2008, Windows Server 2012

### Test Certificate (QIC, sold separately)

QIC is available for each model.

### User's Manual

Product user's manuals can be downloaded from the following URL. You will need Adobe Reader 7 or later by Adobe Systems.

**URL: [www.smartdacplus.com/manual/en/](http://www.smartdacplus.com/manual/en/)**

## MODEL SELECTION GUIDE

### Selection of the system configuration and GM10 type

Model-Type	Internal memory	System Configuration	I/O channels
GM10-1	500MB	Single Unit	0 to 100ch
		Multi Unit	0 to 100ch
GM10-2	1.2GB	Single Unit	0 to 100ch
		Multi Unit	0 to 420ch



### I/O Modules

Model	Suffix code	Product name	Description	Number of channels	Measurement interval (shortest)
GX90XA	-10-C1N-□N	Analog Input Module	DC current (mA), DC current standard signal (4-20 mA)	10	100 ms
	-10-L1N-□N		DC voltage, standard signal, thermocouple (TC), DI (voltage, contact), and DC current (by adding an external shunt resistor)		500 ms
	-10-U2N-□N		DC voltage, standard signal, thermocouple (TC), resistance temperature detector (RTD), DI (voltage, contact), and DC current (by adding an external shunt resistor)		100 ms
	-10-T1N-□N		DC voltage, standard signal, thermocouple (TC), DI (voltage, contact), and DC current (by adding an external shunt resistor)		1 s
GX90XD	-16-11N-□N	Digital Input Module	Remote control input, pulse input	16	100 ms
GX90YD	-06-11N-3N	Digital Output Module	Alarm output, etc	6	100 ms (update interval)
GX90WD	-0806-01N-3N	Digital Input/Output Module	Remote control input, pulse input	DI: 8 DO: 6	100 ms
GX90XP	-10-11N-□N	Pulse Input Module	Pulse input (flow sum and the like)	10	100 ms

### Single unit system configuration (up to 100 channels)

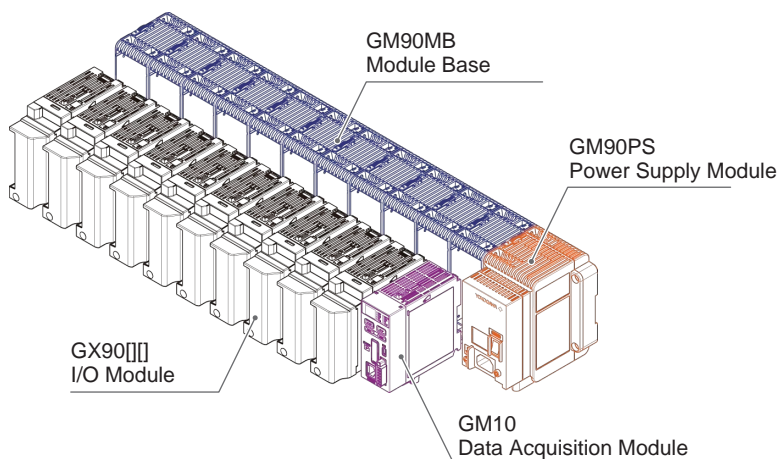

#### Configuration example (maximum)

GM10: 1  
GM90PS: 1  
GX90□□: 10  
GM90MB: 11

9	8	7	6	5	4	3	2	1	0	← Slot number
GM90MB	GM90MB	GM90MB	GM90MB	GM90MB	GM90MB	GM90MB	GM90MB	GM90MB	GM90MB	GM90MB
GX90□□	GX90□□	GX90□□	GX90□□	GX90□□	GX90□□	GX90□□	GX90□□	GX90□□	GX90□□	GM10
										GM90PS

### Multi unit system configuration (up to 420 channels)

Main unit

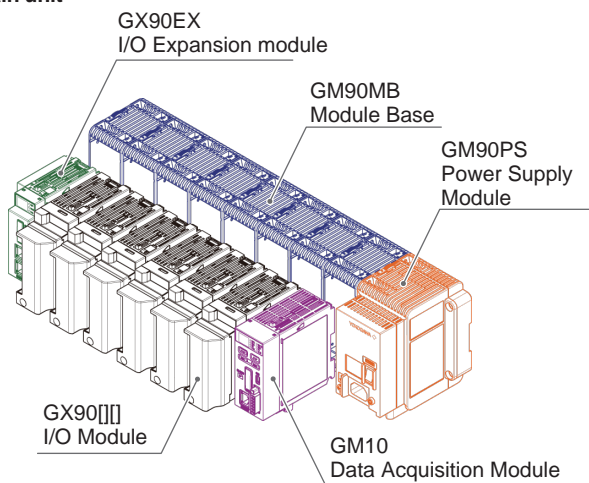

Sub unit

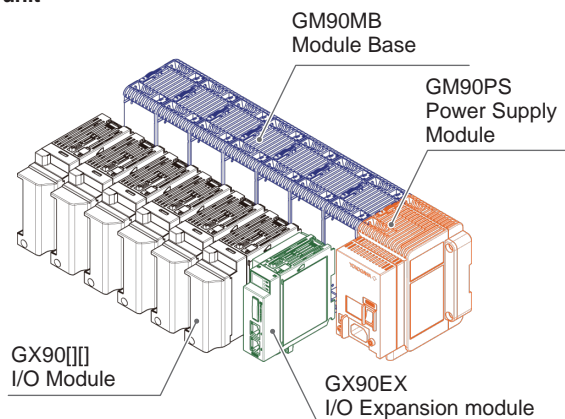

#### Main unit configuration example (maximum)

- GM10: 1
- GM90PS: 1
- GX90 I/O: 6
- GX90EX: 1
- GM90MB: 8

#### Sub unit configuration example (maximum)

- GM90PS: 6
- GX90 I/O: 36
- GX90EX: 6
- GM90MB: 42

	5	4	3	2	1	0	←Slot number		
Main Unit (Unit 0)	GM90MB	GM90MB	GM90MB	GM90MB	GM90MB	GM90MB	GM90MB	GM10	GM90PS
	GX90EX	GX90 I/O	GX90 I/O	GX90 I/O	GX90 I/O	GX90 I/O	GX90 I/O		

	5	4	3	2	1	0	←Slot number	
Sub Unit (Unit 1)	GM90MB	GM90MB	GM90MB	GM90MB	GM90MB	GM90MB	GM90MB	GM90PS
	GX90 I/O	GX90 I/O	GX90 I/O	GX90 I/O	GX90 I/O	GX90 I/O	GX90EX	

	5	4	3	2	1	0	←Slot number	
Sub Unit (Unit 2)	GM90MB	GM90MB	GM90MB	GM90MB	GM90MB	GM90MB	GM90MB	GM90PS
	GX90 I/O	GX90 I/O	GX90 I/O	GX90 I/O	GX90 I/O	GX90 I/O	GX90EX	

	5	4	3	2	1	0	←Slot number	
Sub Unit (Unit 3)	GM90MB	GM90MB	GM90MB	GM90MB	GM90MB	GM90MB	GM90MB	GM90PS
	GX90 I/O	GX90 I/O	GX90 I/O	GX90 I/O	GX90 I/O	GX90 I/O	GX90EX	

	5	4	3	2	1	0	←Slot number	
Sub Unit (Unit 4)	GM90MB	GM90MB	GM90MB	GM90MB	GM90MB	GM90MB	GM90MB	GM90PS
	GX90 I/O	GX90 I/O	GX90 I/O	GX90 I/O	GX90 I/O	GX90 I/O	GX90EX	

	5	4	3	2	1	0	←Slot number	
Sub Unit (Unit 5)	GM90MB	GM90MB	GM90MB	GM90MB	GM90MB	GM90MB	GM90MB	GM90PS
	GX90 I/O	GX90 I/O	GX90 I/O	GX90 I/O	GX90 I/O	GX90 I/O	GX90EX	

	5	4	3	2	1	0	←Slot number	
Sub Unit (Unit 6)	GM90MB	GM90MB	GM90MB	GM90MB	GM90MB	GM90MB	GM90MB	GM90PS
	GX90 I/O	GX90 I/O	GX90 I/O	GX90 I/O	GX90 I/O	GX90 I/O	GX90EX	

---

## Trademarks

The TCP/IP software used in this product and the document for that TCP/IP software are based in part on BSD networking software, Release 1 licensed from The Regents of the University of California.

SMARTDAC+ is a trademark of Yokogawa Electric Corporation.

Microsoft, MS, and Windows are trademarks or registered trademarks of Microsoft Corporation in the United States and other countries.

Pentium is a registered trademark of Intel Corporation.

Modbus is a registered trademark of Schneider Electric.

Kerberos is a trademark of MIT.

Bluetooth is a trademark or registered trademark of Bluetooth SIG Inc.

Other company names and product names appearing in this document are registered trademarks or trademarks of their respective holders.

The company and product names used in this manual are not accompanied by the registered trademark or trademark symbols (® and ™).